

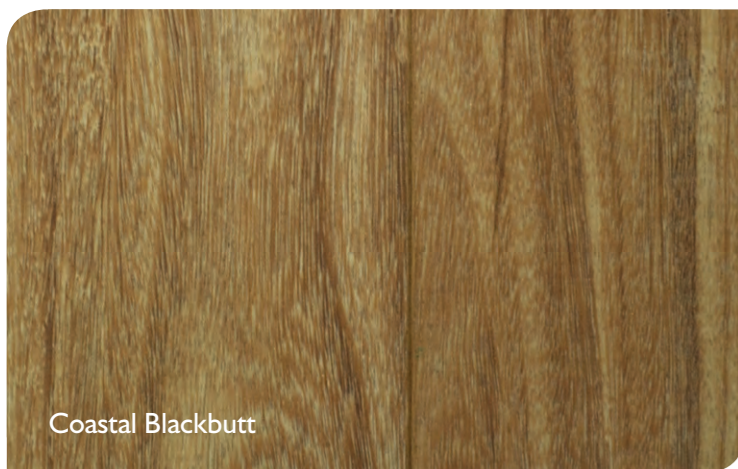

**Australian Longboard Timber Colours**

[www.embelton.com](http://www.embelton.com)



Coastal Blackbutt

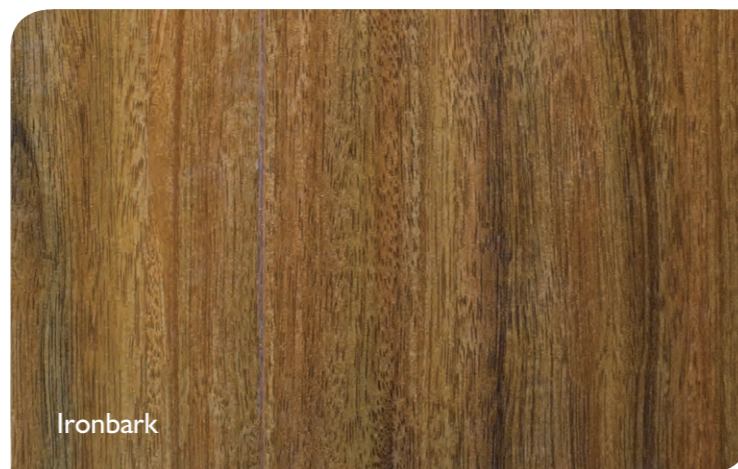

Ironbark

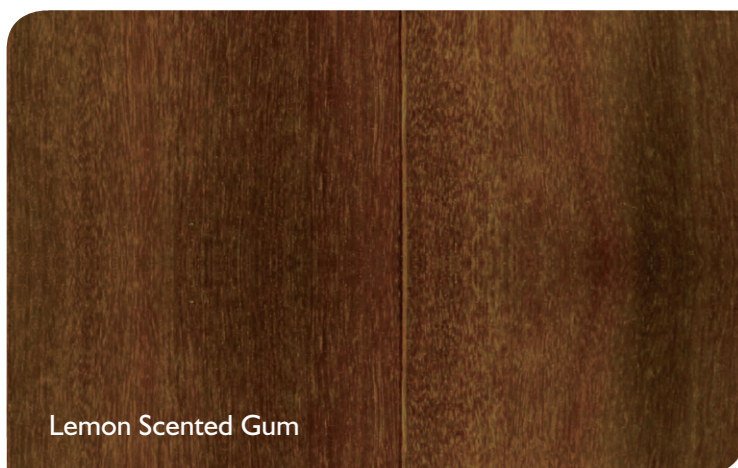

Lemon Scented Gum



Spotted Gum

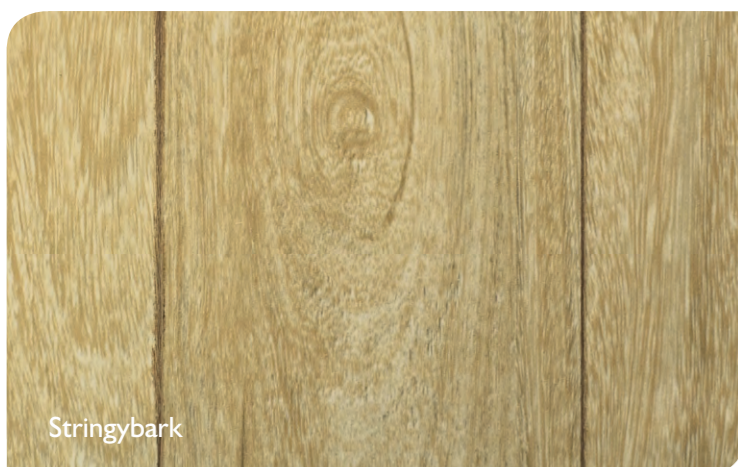

Stringybark

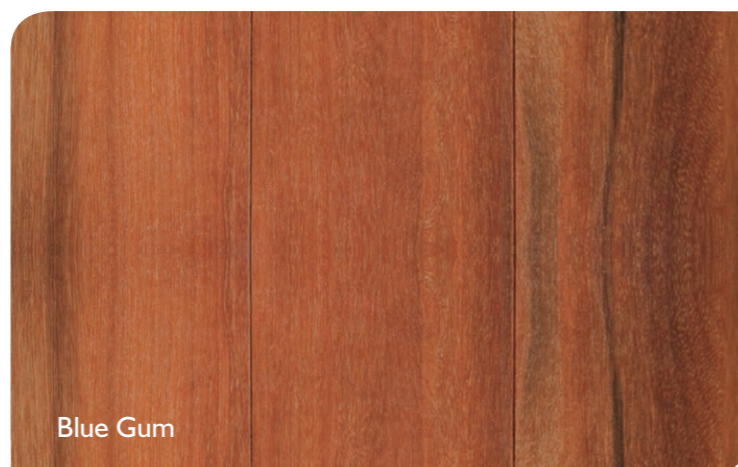

Blue Gum

**Care & Maintenance**

Caring for your Laminate Floor is easy. Occasionally vacuum or sweep the floor to remove dirt and debris. A damp mop can be used regularly, and nail polish remover will get rid of those tough spots. For preventative care, walk off mats at entrances should be considered, as well as area rugs in high wear spots, and felt protectors or casters attached to chair, table and appliance legs.



The look of wood  
- the durability of laminate





Stylish. Affordable. Tough.

# The look of wood

## – the durability of laminate



Australian Longboards – combining the look of classic Australian timbers with the hard wearing qualities of laminate.

### Environmentally sound choice

Australian Longboards create the appearance of a genuine timber floor. Made from High Density Fibreboard (HDF), manufacturing places few demands on our environment, making it the ultimate sustainable floor.

### Stylish

Available in 6 popular Australian timber colours, it readily matches the most stylish interiors.

### Robust

Tougher than traditional engineered timber floors, Australian Longboards come with a 25 year structural guarantee. Resistant to stains, moisture, scratches, indentation and cigarette burns, Longboards are ideal for family flooring or commercial installations.

### Manufacturing warranted to the highest quality standards

Australian Longboards are manufactured to the highest European standards, and come with a comprehensive 25 year domestic warranty to ensure a lifetime that will span generations.

### Hygienic

Unlike carpet, laminate floors won't attract dust mites or bugs. They are easy to clean, making for the perfect hygienic floor - especially important for kids and pets.

### Versatile

Australian Longboards can be laid over almost any type of sub-floor, including existing wooden floors and even concrete slabs.

### Perfect for commercial installations

Australian Longboards are durable, easy to maintain and, unlike solid timber, will not cup, contract or expand, giving one less item for concern in commercial environments.

### Easy to install

The patented Unilin locking system makes installation straightforward and uncomplicated – even suitable for DIY! No glue required - just click and go, to start walking as soon as the floor is laid.

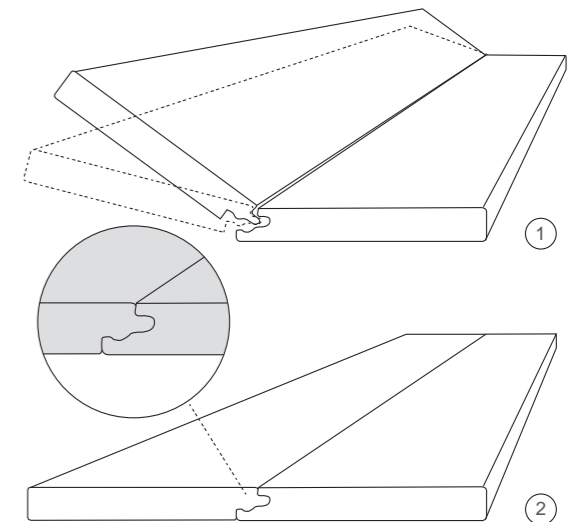

### Technical Specifications:

- Board dimensions: 1800x168x12mm
- 8 boards per pack to cover 2.419 sq.m.
- Sold with the Unilin licensed locking system