

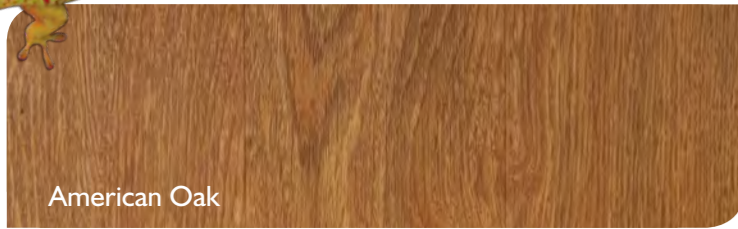

Eco-Tuf Colours

Please note the range may be altered, based on popularity and availability.
For updates, please refer to our website

www.embelton.com



American Oak

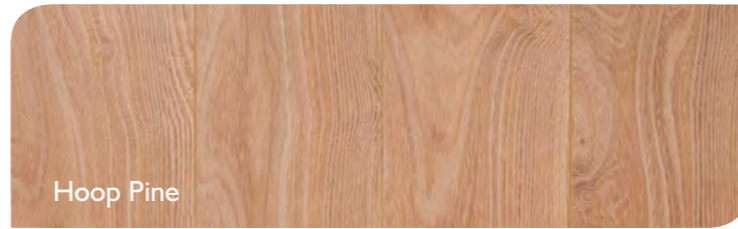

Hoop Pine

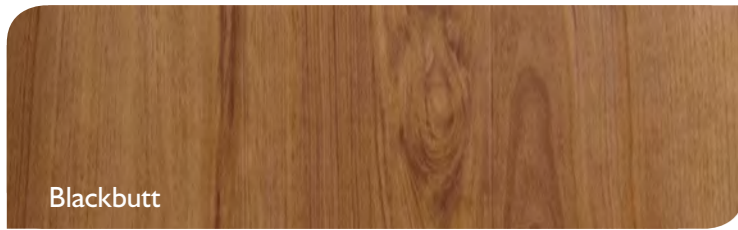

Blackbutt

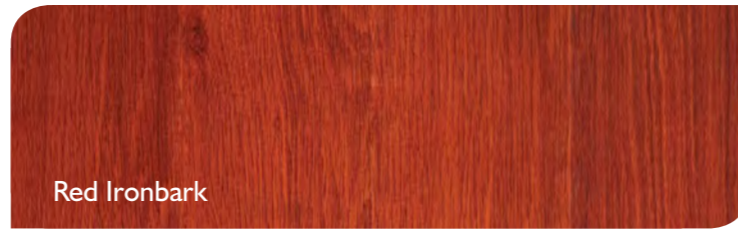

Red Ironbark



Lime Washed Oak

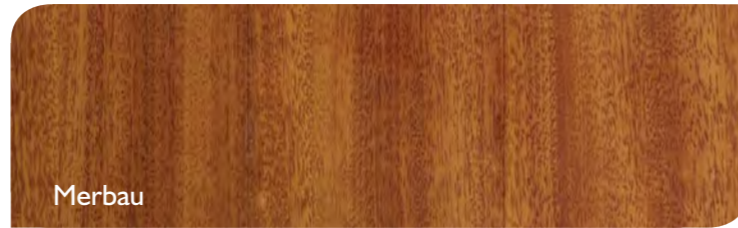

Merbau

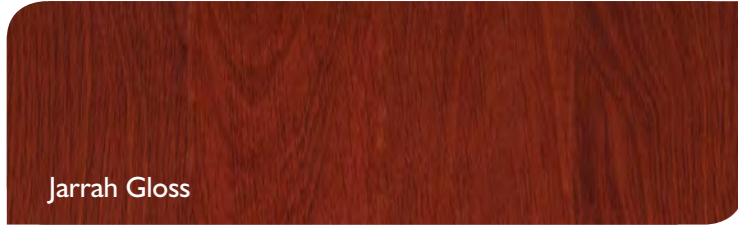

Jarrah Gloss



Chestnut Gloss

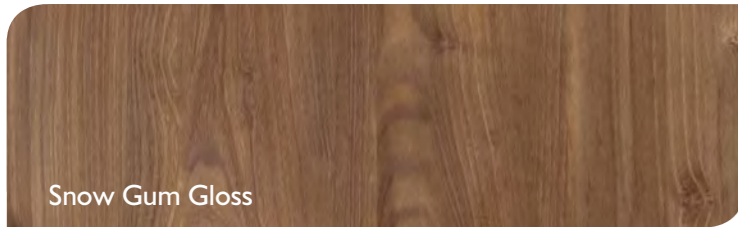

Snow Gum Gloss

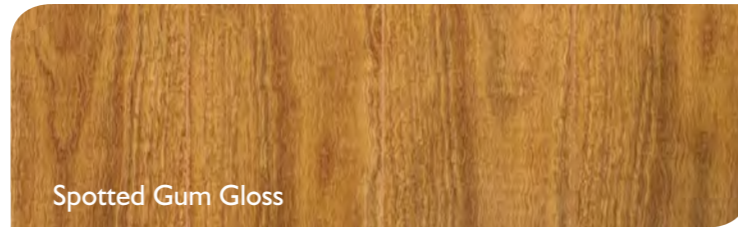

Spotted Gum Gloss

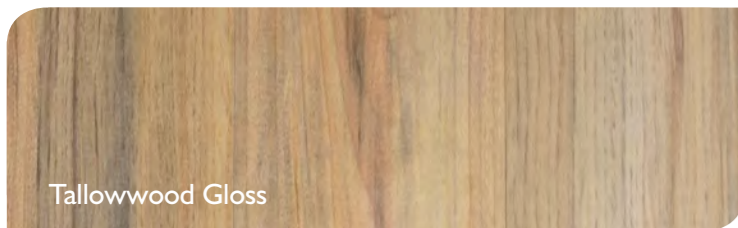

Tallowwood Gloss

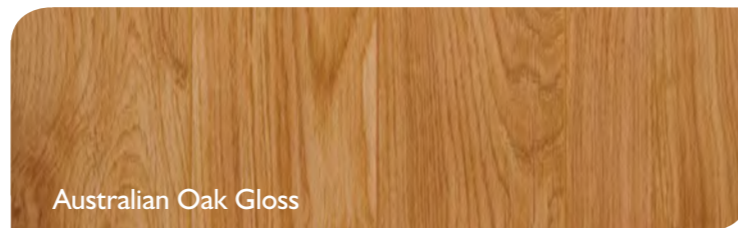

Australian Oak Gloss

Care & Maintenance

Caring for your Eco-Tuf Laminate floor is easy. Occasionally vacuum or sweep the floor to remove dirt and debris. A damp (but not wet) mop can be used regularly. For preventative care, walk off mats at entrances should be considered, as well as area rugs in high wear spots and felt protectors or casters attached to chair, table, and appliance legs.



PRACTICAL • STYLISH • DURABLE

Eco-Tuf Laminate Flooring – high quality timber looking laminate from the name you can trust.



What is Eco-Tuf Laminate Flooring?

Constructed of High Density Fibreboard (HDF) and featuring a photographic layer of quality timbers beneath a clear protective layer of laminate, Eco-Tuf creates the appearance of a genuine timber floor – but without any of the hassles, and at a fraction of the price.

Suitable for all types of installation

Eco-Tuf is easy to clean and maintain, and provides a consistent looking finish. It is suitable for all types of applications, including homes, shops, rental properties and large-scale commercial projects.

The sustainable choice

Manufacturing places few demands on our environment – few natural resources are used, making Eco-Tuf Laminate Flooring a sustainable alternative to timber.

Cleaner than carpet

Unlike carpet, Eco-Tuf Laminate Flooring won't attract dust mites or bugs. They are easy to clean, making for the perfect hygienic floor – especially important if you have children and pets.

Choose between gloss or crystal

Eco-Tuf Laminate Flooring features a choice of gloss or crystal (satin) colours, from a selection of the most popular Australian and imported timber species.

Easy to install

The patented Unilin click system makes installation straightforward and uncomplicated – even suitable for DIY. No glue is required, just click and go – the floor can be used as soon as it is laid. And if a board gets damaged, it can be easily replaced.

Manufacturing warranted to the highest quality standards

Developed in partnership with one of Embelton Flooring's most trusted suppliers, Eco-Tuf meets the highest European standards for laminate flooring. To ensure longevity, Eco-Tuf comes with a comprehensive 25 year domestic and 10 year commercial warranty.

Robust

Tougher than traditional timber floors, Eco-Tuf Laminate Flooring comes with a 25 year structural guarantee. Resistant to stains, moisture, scratches, indentation and cigarette burns, Eco-Tuf Laminate Flooring is ideal for family flooring or commercial installations.

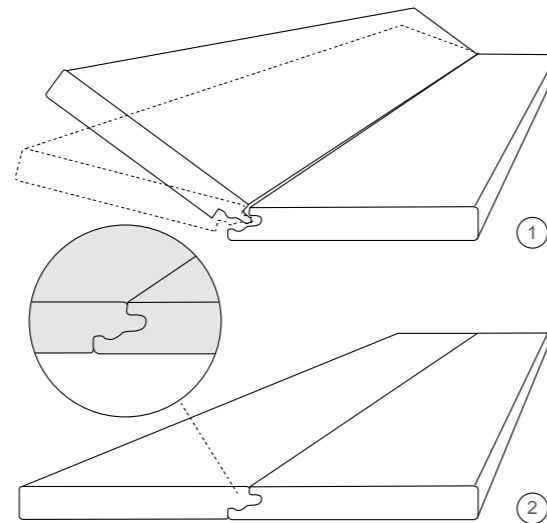

Technical Specifications:

- Board dimensions: 1217x128x8.3mm
- HDF Core 920 to 950Kg/M3
- 12 boards per pack to cover 1.87 sq.m.
- Sold with Unilin click system.

